

By Digital Keys Pty Ltd

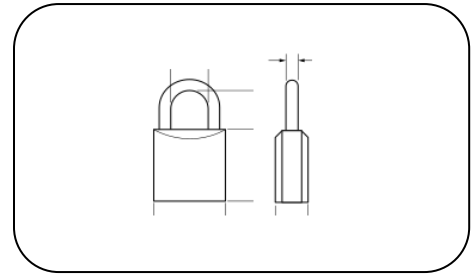

5G IoT Smart Access Control Systems

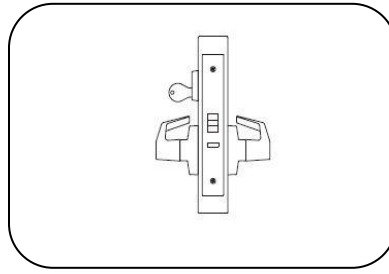
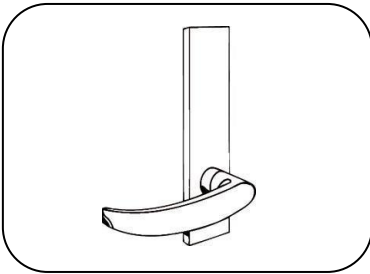

5G IoT Smart Doorlock 3 Hardware Manual



© 2021 Digital Keys Pty Ltd.

The information contained in this document produced by Digital Keys Pty Ltd is solely for the addressee for the purposes for which it has been prepared. Digital Keys Pty Ltd undertakes no duty or accepts any responsibility to any third party who may rely on this document. All rights reserved. No sections or elements of this document may be removed from this document, reproduced, electronically stored or transmitted in any form without the prior written permission of Digital Keys Pty Ltd.

About This Manual

Copyright 2021 by Digital Keys Pty Ltd.
Level 1, 1 Tonsley Blvd,
Tonsley South Australia, Australia 5042

<https://www.digitalkeys.io/>

Edition: 20222405

Version: 1.1

Document number: **MORTISE SMARTLOCK_2.0.DOCX**

This issue replaces all previous issues. All previous issues are invalid. The information in this manual can be changed without prior notice.

Passing on or copying this document, using and providing information on its contents is prohibited unless expressly permitted. Infringements shall be subject to compensation claims. All rights reserved in the case of patent award or listing of a registered design.

The arrangement of information for this document is to the best of our knowledge and belief. Digital Keys assumes no guarantee for the accuracy or completeness of the contents of this document. In particular, Digital Keys cannot be made liable for consequential damages which are due to erroneous or incomplete information. As mistakes can be made despite our best possible efforts, we would be very thankful for any corrections which you may find necessary.

Safety and warning instructions

- This manual outlines the commissioning, installation and operation of a 5G IoT Smart Doorlock
- This equipment may only be used for the purpose specified by the manufacturer.
- This manual should be kept accessible.
- Illegal changes and the use of spare parts as well as accessories that have not been sold or recommended by the manufacturer of this unit can cause fires, electric shocks and injuries. Such measures lead to an exclusion of liability, and the manufacturer accepts no responsibility.
- Repairs may only be carried out by the manufacturer or accredited distributor/re-seller.
- Basis for the guarantee of the manufacturer is the version of the warranty policy for the unit at the time of purchase. No liability is accepted for inappropriate, incorrect manual or automatic setting of the parameters for the device, or its improper use.
- The distributor/re-seller in conjunction with the lock purchaser (if required), is responsible for ensuring that the device is assembled and mounted according to the recognised technical guidelines as well as other valid regulations in the country of use

Contents

- Introduction Summary.....4
- The technology.....4
- Operation.....4
- Flexibility.....4
- The system concept.....4
- The security.....4
- Technical Data.....6
- What’s included.....7
- General information.....8
- Capacitive wake-up button.....8
- Programming.....8
- Operator guidance.....9
- LED light display.....9
- Information on unlocking.....9
- Time Zones.....9
- NFC Tokens/cards.....9
- Battery replacement.....10
- Battery Notifications/monitoring.....11
- Care and maintenance.....11
- Installation.....11

Introduction Summary

This manual outlines the functions of the 5G IoT Mortise Smartlock, how to install and use the product.

The technology

The 5G IoT Smart Doorlock is operated completely independent of any external cable connections (product is battery powered with 2 ER14505H lithium thionyl chloride batteries (+SPC1520 super capacitor) and can be installed and operated where appropriate including outdoors under most weather conditions.

The operation of the 5G IoT Smart Doorlock occurs via 5G IoT technology, combined with NFC technology, and with cloud-based software and smartphone apps.

In order to unlock the lock, any smartphone which can connect to the internet, which has also been authorized, can be used. Smartphones which have NFC in built (most Android phones) which have also been authorized, can be held in front of the lock to gain access (within 2-4 centimeters) from armoured glass. NFC tokens/keycards, which have been authorised can also be used for unlocking. With these authorized devices/tokens, a mechanical coupling is activated for a few seconds that allows the 5G IoT smart padlock to be opened and closed by pulling the shackle up.

Operation

After the 5G-IoT Smart Doorlock has recognised a valid digital key, a mechanical coupling is produced for a few seconds between the CPU and the motor and the unlocking mechanism inside the lock.

Flexibility

The 5G-IoT Smart doorlock is an autonomous door locking system that can manage an unlimited number of users, on any time-limited digital keys, and an unlimited number of locks per account. With this, individual time-limited access rights can be assigned to every user. The fact that every digital key can be authorised for every lock, means a high degree of flexibility is reached. Various access profiles can be set within the locking system.

If a digital key on a NFC card/token or smartphone is lost, the digital key can be deleted without making it necessary to physically attend to the smart doorlock.

The system concept

The 5G IoT Mortise Smartlock is complemented by;
Access Management Cloud Based Software
Digital Keys Apps (Android and iOS available for unlimited downloads from online app stores)
Digital Keys NFC keycards and tokens (3 cards provided). Please check with your local distributor to purchase more.

The security

5G IoT is part of local mobile networks (part of the 5G standards), fully managed with standardized security to guarantee the credential and integrity of all data running through it. 5G IoT has passed security protocols as outlined by 3GPP/GSMA, the organizations responsible for managing global mobile networks.

The 5G IoT module chipset included in our 5G IoT smart locks applies 2048 bit RSA encryption. All communications are running on HTTPS 128 bit military grade encryption between all the vertical applications including software and hardware. Between the telco's mobile network, and the IoT device management platform a layer of Internet Protocol Security (IPSEC) is provided. The Telecommunication company on some occasions, also provides a dedicated VPN for further security and reliability.

Technical Data

Display elements:	1 x LED blue light (numberpad)
Acoustic signal:	Signal transmitter
Battery:	4AA standard alkaline batteries
Battery life:	approx. 2 years or approx. 20.000 operations
Temperature range;	-50 to 60°C
Relative humidity:	20 to 95% RH
Dimensions:	L300mm x W50mm x B22mm
Surface housing	Stainless steel with armoured glass numberplate
5G IoT Module:	Telit 310gWW 5G-IoT/LTE-M module(CAT-M,3G/4G fallback)
SIM card	5G IoT nano SIM (global roaming or local)
Unlocking methods:	Digital Keys app, NFC keycards (programmed for time-sensitive use with Digital Keys app (and NFC HCE compatible phones), time-sensitive PIN, remote unlock button inside cloud based lock management software (access management software is provided).

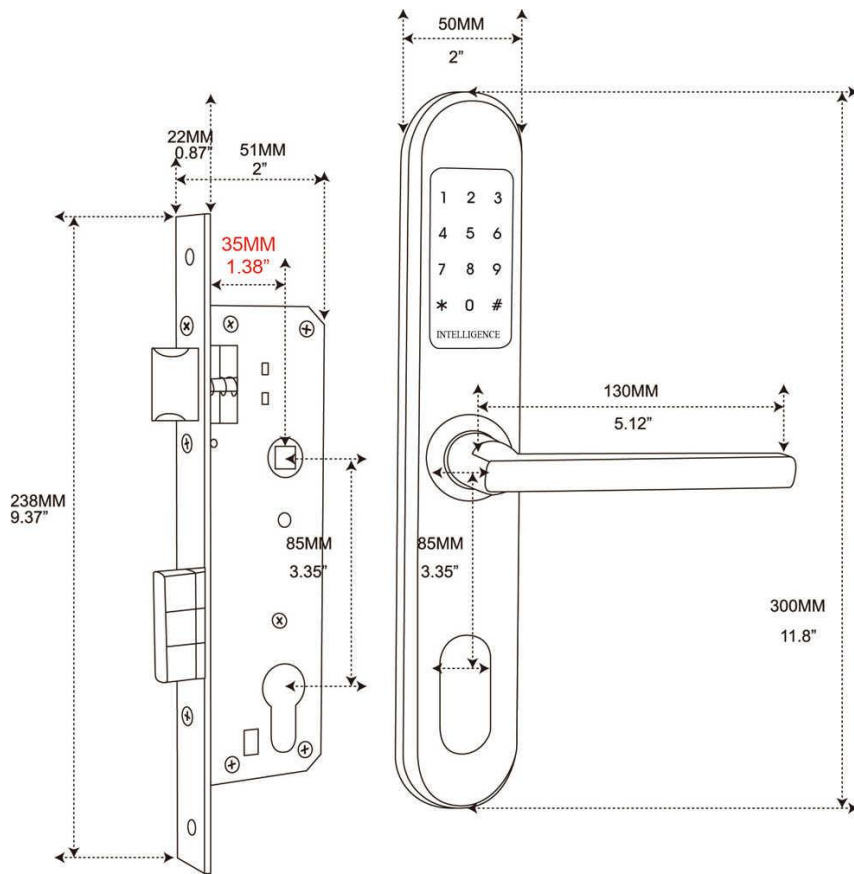

What's included



5G-IoT Mortise Smartlock



EU/ANSI Stainless steel mortise



NFC keycards



Strike plate

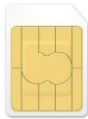

Nano SIM Card

5G-IoT/LTE-M SIM card

General information

Capacitive wake-up button

The 5G IoT Smart Doorlock uses a capacitive wake-up button which must be pressed to unlock the lock. The wake-up button wakes the lock up and prepares it to receive unlock commands over the 5G IoT network, from digital keys app unlocking, and from the access management software unlocking. The wake-up button exists to conserve battery energy so the lock is not always on (it remains mostly in deep sleep mode), waiting to receive commands.

The capacitive wake-up button is the number 1 **1** on the numberpad. see below where green arrow is pointing. The capacitive wake-up button does not need to be pressed for NFC phone unlocking and NFC card unlocking (the NFC in the card and phone wakes up the device when within NFC range 1-5 cm).



Programming

The programming for the 5G IoT Smart Doorlock, can be carried out with our Access Management Software, and the Digital Keys apps (Digital Keys apps are FREE to download from the online app stores Android and iOS). The programming is described in the accompanying software manual. When using NFC phones and NFC tokens/cards, programming of the lock is carried out over the 5G IoT network on the first time the phone or token/card is presented to the door for unlocking. For all future unlocks with NFC, this will be done locally, and commands do not need to be sent over the 5G IoT network everytime. When NFC is used to unlock, the 5G IoT is still used for live audits, live battery status, and live notifications.

Operator guidance

Operation is supported by the blue LED display, as well as by acoustic signals - a buzz sound occurs when the lock has successfully received its command, and the lever handle can then be pulled down to unlock the door.

LED light display

The 5G IoT Smart Doorlock has a blue LED light built in.

There are only 2 different status offered by the LED lights as follow;

1. Flashing blue - lock is awake (after wake-up button is pressed or new batteries inserted) and is connecting to the network (new batteries) or awaiting a command such as an unlock command.
2. Solid blue light - lock has successfully received an authorized unlock command, and is now unlocked, so you can pull shackle up to unlock.

Information on unlocking

To unlock the lock, please follow the instructions below;

1. Hit unlock button on the app (follow instructions on the app, which should say 'unlock command has been sent' and a further instruction to touch the wake up button)
2. Touch the number 1 **1** on the lock numberpad to wake up the lock to unlock it).
3. Blue light flashes whilst unlock command is finalized
4. A buzz noise occurs, blue lights stop flashing and stays on.
5. Pull handle down.
6. Within 10 seconds the lock automatically locks again
7. Pull handle up to engage deadbolt for added security measure.

There is a pause of a few seconds between pressing the wake-up number 1 button and the lock making the buzz noise/flashing blue light indicating the shackle is ready to be pulled up and opened.

When unlocking with NFC (NFC phones and tokens) there should not be any delay in the lock being ready to be opened by pulling the shackle up. NFC phones and tokens must be held within 1-4 centimeters from the numberpad on the lock.

Time Zones

The 5G IoT smart locks use local internet time, which can be set when the locks are first set-up and commissioned by our local distributors. Locks can be programmed to work for a minimal 30 minute timeslot. When the programmed time for the digital keys expires, the unlock icon will disappear from the digital keys app.

NFC Tokens/cards

The 5G IoT smart locks only work with special Digital Keys NFC cards/tokens. The product will not work with any NFC cards bought online from third parties, or from non-certified 5G IoT smart lock re-sellers. 2 NFC tokens are provided in every pack. Please contact Digital Keys or your local distributor/re-seller if you need to buy more keycards/tokens.

Battery replacement

1. Slide the black battery case cover down on the back of the lock – see below

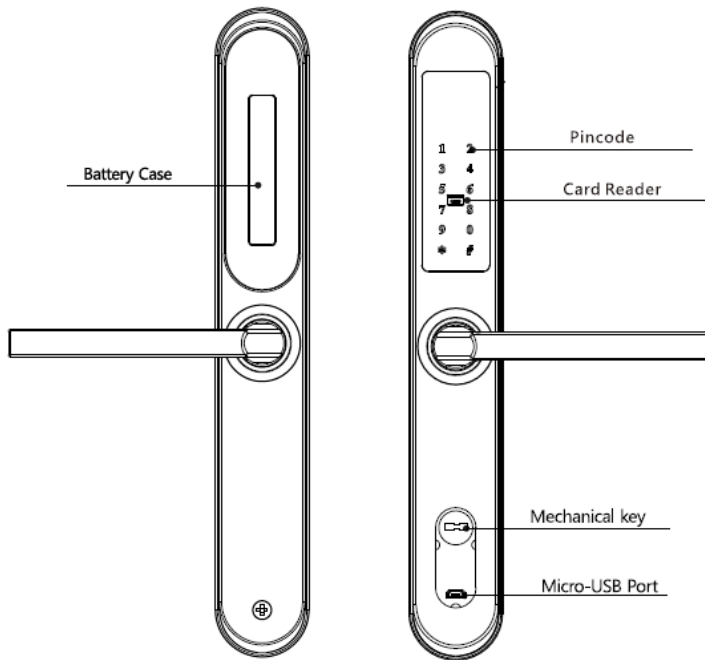

2. Place batteries into the battery holder as shown below.

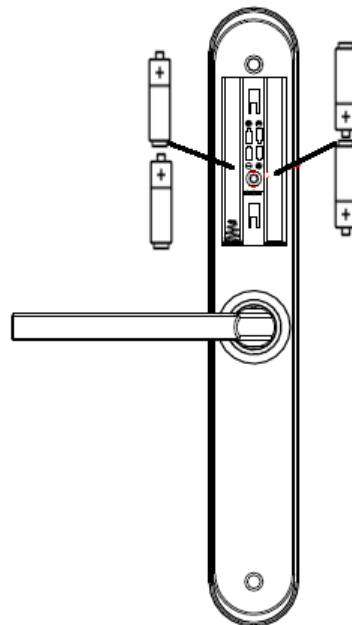

3. Slide the cover back in place

Note: No digital keys are deleted during the battery changeover.

Battery Notifications/monitoring

A live battery status is shown in the access management software (please see section 2 User guide for more information). Account administrators can set up email notifications for when battery status gets below 10%.

Care and maintenance

The 5G IoT Smart Doorlock is maintenance-free. At no time may they be oiled or greased with lubricants containing mineral oil. Cleaning may only be carried out with non-stick, residue-free cleaning and disinfection agents. No abrasive cleaning agents, or acids may be used for care and maintenance. Equally, pressure washers may not be used. Although the 5G IoT Smart Doorlock is weatherproof we don't suggest the use of a high pressure hose to spray product, as it can lead to damage and liability exclusion.

Installation

Please follow the installation instructions below

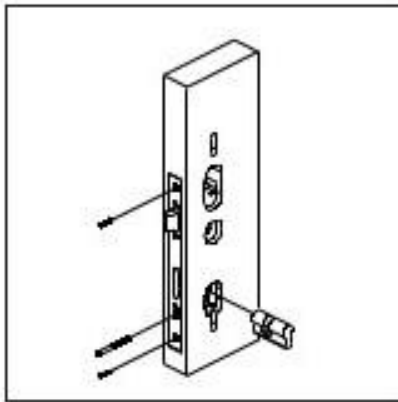

a Drill the holes on the door and then install the mortise into the door;

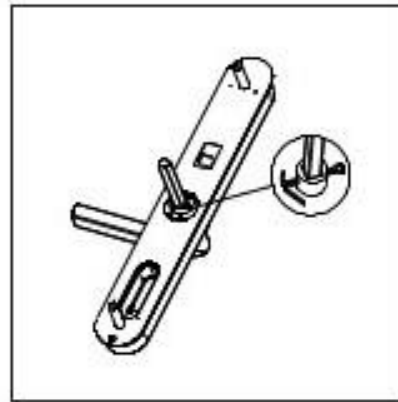

b Install the spindle into the handle hole in the front panel, and then insert the rod and fasten it;

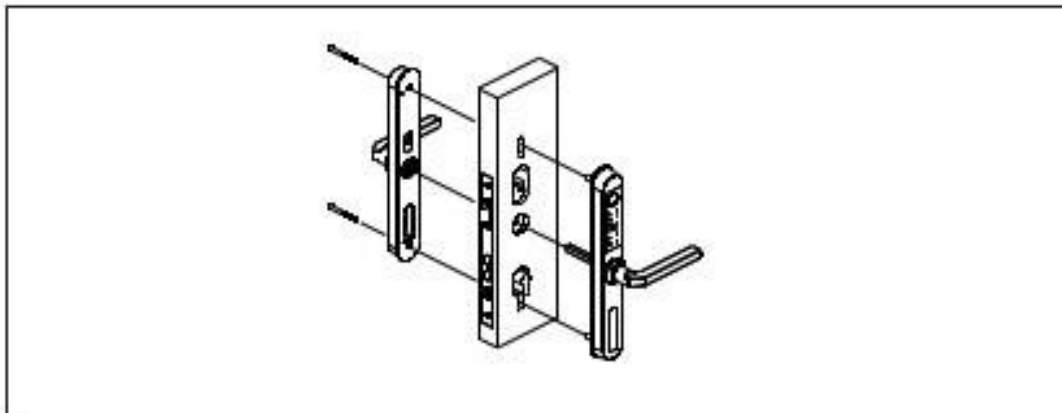

c Install the front panel on the door
Connect the cable between the front and back panels

d Install the back panel on the other side of door, and then fasten both panels

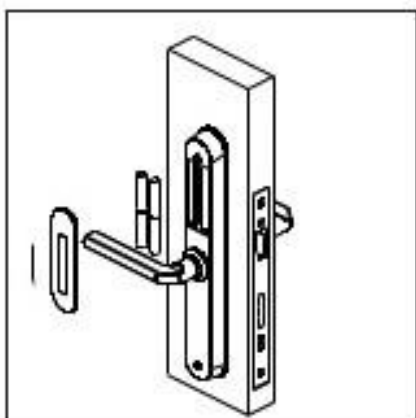

e Install the batteries

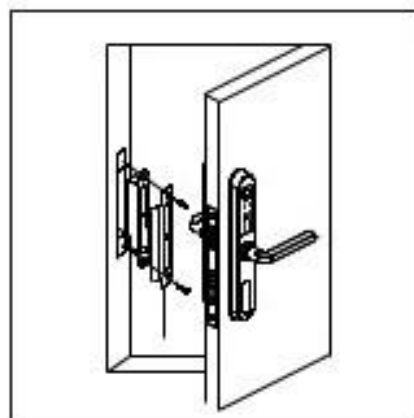

f Test the installation to confirm the installation is successful

FOR MORE INFORMATION PLEASE CONTACT DIGITAL KEYS



Digital Keys Pty Ltd copyright 2020
Level 1, 1 Tonsley Blvd, Tonsley,
South Australia, Australia
<https://www.digitalkeys.io/>
info@digitalkeys.io